

# Speaker 538 LED Strobe Light

## Pipe Mount



### Description

Durably designed, the model 538 is made with an acrylic lens that resists scratching and scuffing, so it lasts longer than stock warning and indicator lights. Using a solid optic design with a single LED, this industrial warning light utilises multiple LED colours instead of coloured lenses, giving you a cleaner, tidier package with improved performance!

### Features

- Available in strobe warning lights or indicator lights
- Strobe warning light colours: amber, red, green, blue, & white
- Indicator light colours: red/green
- Utilises a single LED for different colours instead of coloured lenses
- Polycarbonate housing
- 12-80 VDC input and operating voltage
- Impact-resistant acrylic lens
- Pipe mount

### Application

Construction, agriculture, Industrial, material handling, forklifts, warehouses, mining, railroad, specialty vehicles, trucks and buses

### Tech Specs

Type	LED Strobe Light
Colours Available	Amber, Red, Green, Blue, White, Red/Green
Beam Pattern	Warning - Strobe
Class	Class III
Flash Rate	60 +/- 10 fpm
Input Voltage	12-80V DC
Operating Voltage	12-80V DC
Red Wire	Positive
Black Wire	Negative
Current Draw	0.256A @ 12V DC, 0.088A @ 48V DC, 0.076A @ 80V DC (538-A, 538-R, 538-G, 538-B, 538-W) 0.178A @ 12V DC (Red LED) (538-RG) 0.188A @ 12V DC (Green LED) (538-RG) 0.073A @ 48V DC (Red LED) (538-RG) 0.076A @ 48V DC (Green LED) (538-RG) 0.067A @ 80V DC (Red LED) (538-RG) 0.068A @ 80V DC (Green LED) (538-RG)
Shape	Round
Outer Lens Material	Clear Acrylic
Housing Material	Polycarbonate
Housing Color	Black
Mounting Type	Pipe Mount
Minimum Operating Temp.	-40 °C / -40 °F
Maximum Operating Temp.	65 °C / 149 °F
Connector or Wiring	13.5" Bare Leads
Weight	0.30 lbs / 0.14 kgs
Shipping Weight	1.51 lbs / 0.68 kgs
Dimensions (WxHxD)	2.79 x 3.61 x 2.79 inches (70.80 x 91.60 x 70.80 mm)

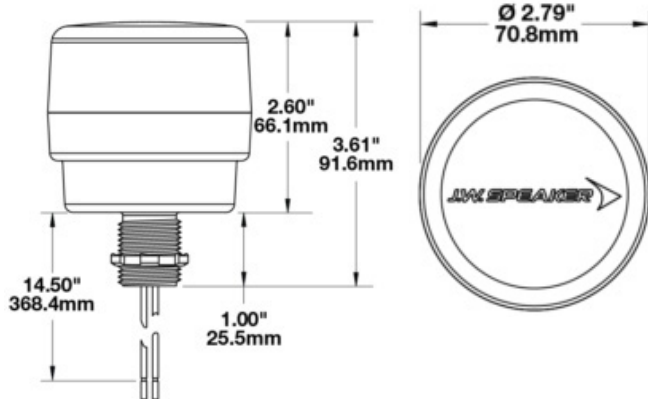

Part No.	Colour	Voltage	Amps (12V)
538-A	Amber	12-80V DC	0.256A
538-R	Red	12-80V DC	0.256A
538-G	Green	12-80V DC	0.256A
538-B	Blue	12-80V DC	0.256A
538-W	White	12-80V DC	0.256A
538-RG	Red/Green	12-80V DC	0.178A (Red LED), 0.188A (Green LED)



Authorised Importer and Master Distributor

