

J.W. Speaker A527

5" x 10" LED "Keep Out" Zone Light



Description

The J.W. Speaker 527 adds a new level of safety to mining and construction sites. It projects a large "Keep Out" zone of red light onto the ground to alert workers and vehicles to stay out of potentially hazardous work areas, such as the swinging path of a shovel or drag line.

Features and Benefits

- Lens: durable glass
- Xenoy housing and universal trunnion mount
- Electrical Connection: integrated 2-Pin Deutsch Weatherproof Socket (DT04-2P)
- Surge: 150V Peak @ 1Hz-100 Pulses
- Dim (DxWxH): 4.02x10.18x4.87" (102.3x258.5x128.8mm)
- Weight: 2.60 lbs (1.18kg)
- Warranty: 5 years, IP Rating: IP69K

Applications

Construction, Industrial, Mining.

Tech Specs

Lens Pattern	Red "Keep Out Zone"
Lens Material	Glass
Housing Material	Xenoy
Technical	527 RED - 12/24V 12-24V DC Input 10-30V DC Operating Voltage 1.60 Amps @ 12V DC 0.85 Amps @ 24V DC Raw Lumen Output: 720 Effective Lumen Output: 670
Mounting Hardware	(x2) M8-1.25 x 25 Mounting Bolts, M8 Split Lock Washer, Hex Nut M8-1.25 SS
Mounting	Universal Pedestal Mount
Mating Connector	Integrated 2-Pin Deutsch Weatherproof Socket (DT04-2P)
Weight	2.75lbs
Standard Compliance	Sealed to IP69K
Additional Information	Wires: Red=Power, Black=Ground Transient Spike Protection: Transient Spike Protection: 150V peak @ 1 HZ-100 Pulses

Part No.	Beam	eLumens	rLumens	Voltage	Amps (24V)	Watts
527R	Red Zone	670 Lu	720 Lu	12-24V	0.85A	20W
527G	Green Zone	670 Lu	720 Lu	12-24V	0.85A	20W
527A	Amber Zone	670 Lu	720 Lu	12-24V	0.85A	20W
527W	White Zone	670 Lu	720 Lu	12-24V	0.85A	20W

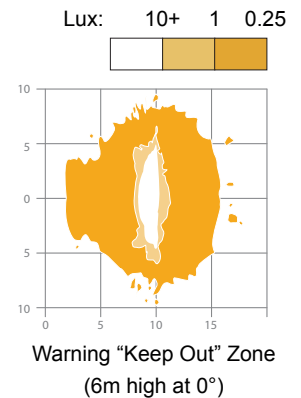
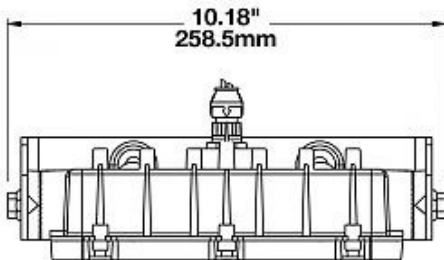
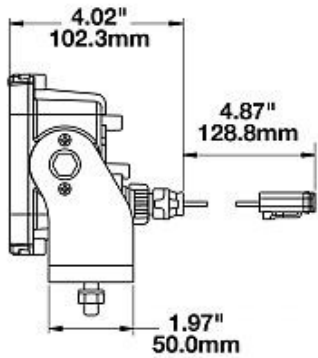
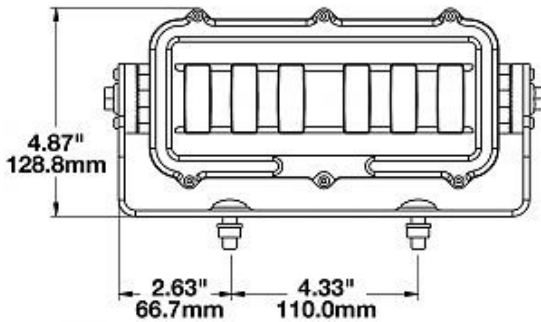

Authorised Importer and Master Distributor

