

ABL QL Blue/Red LED



Description

The QL Blue / Red Arrow LED series work lights are designed to exceed everyday demands in all applications.

Features

- Specific Blue / Red Arrow version
- Ensures a visible sharp-edged warning signal on the floor
- For an increased safety environment.

Applications

Handling equipment such as forklifts

Tech Specs

Bulb	LED Blue - LED Red Optional
Lifetime	20,000 hours
Light Pattern	Sharp-edged Spot
Consumption	7W
Voltage	Multi 12-100V
Intensity	0.3A @ 24V
Weight	0.8kg
Vibration resistance	5 Grms from 24Hz to 2000Hz
Load Dump	125V Continuous
	200V 100 ms
	1800V 50 µs
Polarity	Protected against reversed polarity
Water Tightness	IP68/69K
Operating Temperature	-40°C to +85°C
Mounting Options	Pedestal, Suspended or Side Mount
Salt Spray	ISO 9227
Lens	PC lens
Warranty	20,000 operating hours or 5 years

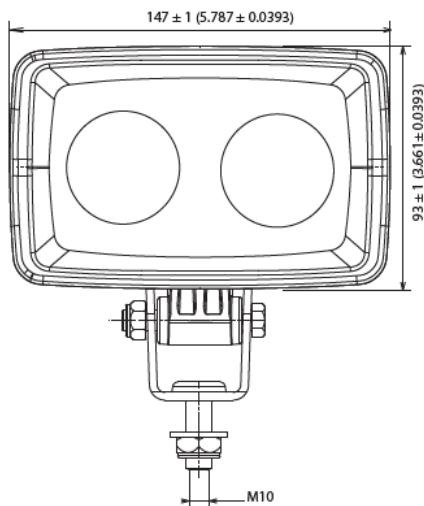
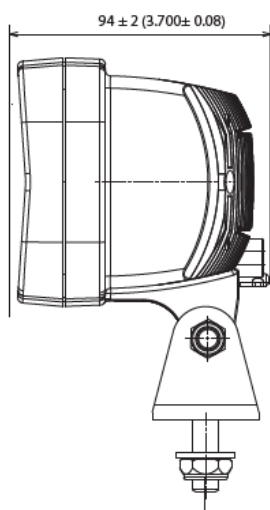

Part No. Description

QLBLUE	ABL QL Blue Arrow LED
QLRED	ABL QL Red Arrow LED



Authorised Importer and Master Distributor

