

# ECCO 500 Series

## Surface Mount Tonal Alarm

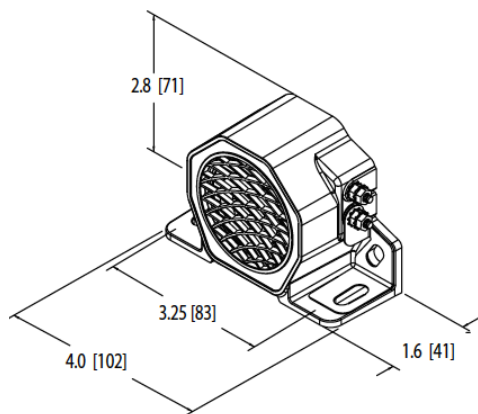

### Description

ECCO's most compact and popular line of back-up alarms, the 500 Series provides a cost-effective warning solution with ECCO quality and reliability. Compact size and universal mounting bracket maximizes location options, self grounding with stud terminal connections, sealed in epoxy for protection against dust, moisture, and vibration.

### Features and Benefits

- Compact size and universal mounting bracket maximizes location options
- Self grounding (except 575)
- Sealed in epoxy for protection against dust, moisture, and vibration
- Temperature Range: -40°F to +185°F (-40°C to +85°C)

### Approvals

Utility vehicles, construction vehicles, refuse trucks, tow trucks, light mining vehicles

### Tech Specs

Voltage	12-24V DC
Amps	0.1A (505), 0.2A (SA951, 520), 0.4A (SA950), 0.9A (575), 1.0A (530)
Decibels	77-97dB (SA9510), 87-102dB (SA950), 87dB (505), 97dB (520), 102dB (530, 575)
Connection	8-32 uni stud
Approvals	SAE Type D (505), SAE Type F (530), SAE Type B (575), IP65 (505, 520), AMECA (505, 530) CE, R10, UL
Dimensions (WxHxD)	1.6x2.8x4.0 inches (41x71x102mm)
Warranty	2 Years

Part No.	Description
520	Smart Alarm, 12-24V DC, 0.2A, 97Db, SAE Type C, CE, R10, UL, AMECA, IP65
530	Smart Alarm, 12-24V DC, 1.0A, 102Db, SAE Type F, CE, R10, UL, AMECA, IP65
SA951	12-48V DC, 77-97Db, 0.2A, CE, R10, UL
SA950	12-24V DC, 82-102Db, 0.4A, CE, R10, UL
505	12-24V DC, 87Db, 0.1A, SAE Type D, CE, R10, UL, IP65, AMECA
575	12-24V DC, 102Db, 0.9A, SAE Type DB CE, R10, UL



Authorised Importer and Master Distributor

