

ECCO ED3779 Series

SAE Class II Multipurpose Light



Description

The ED3779 Series wide-angled LED warning light provides the functionality of a warning light, allowing the vehicle's safe arrival to the scene, plus a worklight to create a safe, bright working environment at the scene all in a single package. This unique directional utilizes three rows of lighting to produce a bright, off-angle, 180-degree lighting spread. SAE Class I light output, synchronization capability and the choice of 29 flash patterns for single-color and 69 flash patterns for dual-color allows the creation of an attention-getting, dual-color warning system with half the number of lights typically required.

Features and Benefits

- 12-24 VDC, 1.7 Amps
- Steady burn override for worklight functionality
- Multi-Surface mount
- Syncable with ECCO's ED3766, ED3706, ED3712, ED3701/2, ED3700, ED3777 series lights
- Durable IP67 rated for dust and water resistance
- Offers flexibility with multiple surface mounting applications
- Temperature Range: -22°F to +122°F (-30°C to +50°C)

Tech Specs

Voltage	12-24V DC
Amps	1.7A
Mount	Surface
Flash Pattern	23
Approvals	SAE Class I, California Title 12, IP67, R10, R65, RoHS
Warranty	5 Years

Part No.

Description

ED3779A	Single, 29 Flash Patterns, Amber
ED3779R	Single, 29 Flash Patterns, Red
ED3779AB	Dual, 69 Flash Patterns, Amber / Blue
ED3779AC	Dual, 69 Flash Patterns, Amber / Clear
ED3779AR	Dual, 69 Flash Patterns, Amber / Red
ED3779AG	Dual, 69 Flash Patterns, Amber / Green

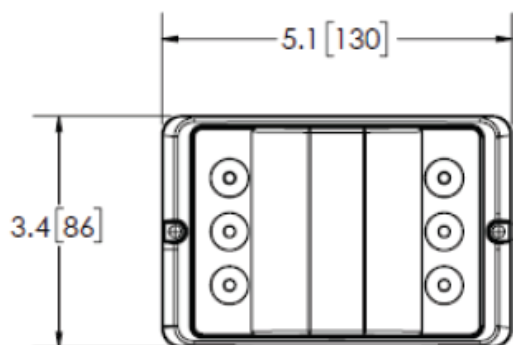

Authorised Importer and Master Distributor

