

Vision X 10W Junction Box

Corrosion Resistant Series

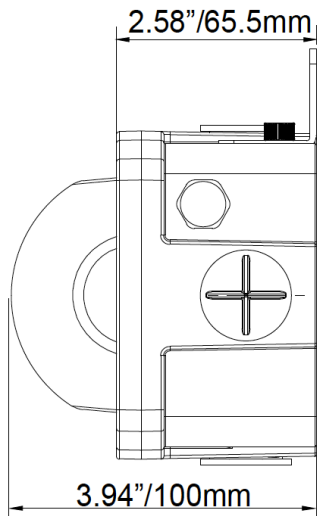
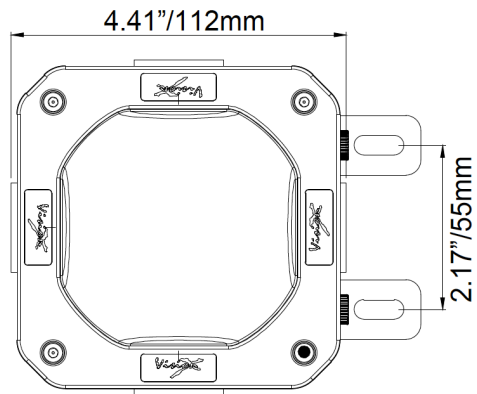

Description

The 10-Watt All-In-One Junction Box LED Light is IP-68/IP69K rated and UL1598a rated for wet locations. Designed to fight against acid mist environments, the 10W is engineered with a plastic tri-coated aluminum housing.

Features and Benefits

- Protective Coating Eliminates Corrosion in High-Risk Environments
- Easy Pole or Ceiling Mounting Options
- 100 Watt Halogen Bulb Replacement
- UL Certified, IP68/IP69K Rating

Application

Industrial and General Area Lighting

Tech Specs

Fixture Weight	2lbs (0.9kg)
Shipping Weight	4lbs (1.8kg)
Mounting	(4) 3/4" NPT - SIDES
LED	5630 (LG) X 40EA
Lumens	1,000lm
Beam Pattern	180° Ultra Wide Flood
Wattage	10W
Amp Draw	0.09A @ 115V AC 0.04A @ 230V AC 0.04 @ 277V AC
Color Temperature	5000K
Operating Voltage	90-264V AC 127-370V DC
Lifespan	50,000hrs
Frequency	47-63Hz
THD	<20% (@load≥50% 115VAC,230VAC) (@load≥75% / 277VAC)
Power Factor	≥ 0.98/115VAC ≥ 0.95/230VAC ≥ 0.92/277VAC
Short Circuit	Constant Current Limiting
Polarity	Reverse Polarity Protection
Housing Material	Plastic Tri-Coated Aluminium
Lens	Polycarbonate
Finish	Gloss Yellow
EMC Emission	Compliance to EN55022, EN61000-3-2 Class A, EN61000-3-3
EMC Immunity	Compliance to EN55024, EN61000-4-2,3,4,5,6,8,11; light industry level(surge 2KV), criteria A
Ingress Protection	IP68/69K, UL1598a Marine
Vibration Rating	15.6Grms
Dimensions (WxHxD)	4.41" x 4.41" x 3.94" inches (112 x 112 x 100 mm)
Warranty	5 Years

Part No.

Description

LSYSM40180F	180° Ultra Wide Flood, Frosted Lens
-------------	-------------------------------------



Authorised Importer and Master Distributor

