

# ECCO ED3794 Ultraflex Series

## Dual-Colour Flexible LED Light



### Description

ECCO's UltraFlex is a versatile directional warning light that can be mounted on flat or curved surfaces up to 120° with self-adhesive, very high bond tape. Its 12 dual-colour LEDs provide exceptional output with combinations of amber and white colour available. The light heads are protected in a clear, silicone housing that can flex while resisting yellowing and warping. A two-bolt bezel is also included for easy installation on flat surfaces.

### Features and Benefits

- 69 flash patterns including steady burn
- Flexible housing adapts to curved surfaces up to 120°
- Silicone lens with Dow Corning material, prevents yellowing or aging
- Included bezel for two-bolt mount on flat surfaces or VHB tape mount
- Sync-capable

### Tech Specs

Voltage	12-24V DC
Color	Amber / Clear, Blue / Amber, Blue / Clear, Red / Amber, Red / Blue, Red / Clear
Flash Pattern	69
Mount	2 Bolt
Amps	0.8A
Temp. Range	-30°C to 50°C (-22°F to 122°F)
Approvals	SAE CLASS I, SAE CLASS II, CAL13, R65, R10, CE, IP67, IP69K
Warranty	5 Years

Part No.	Description
ED3794AW	Amber and Clear LED Color, 0.8A
ED3794BA	Blue and Amber LED Color, 0.8A
ED3794BW	Blue and Clear LED Color, 0.8A
ED3794RA	Red and Amber LED Color, 0.8A
ED3794RB	Red and Blue LED Color, 0.8A
ED3794RW	Red and Clear LED Color, 0.8A

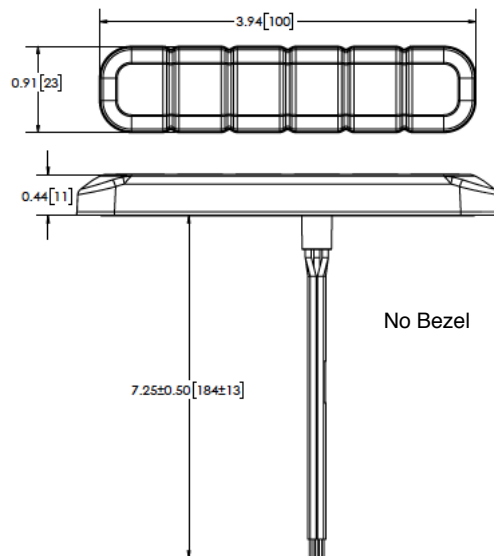
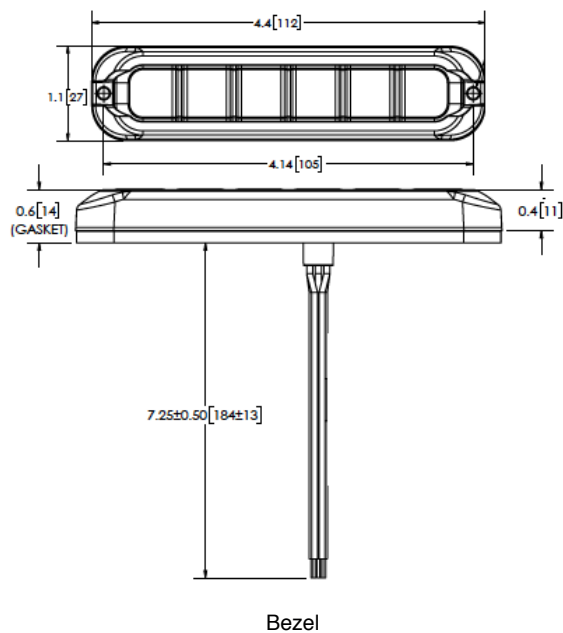

Authorized Importer and Master Distributor

