

# PreView Sentry Plus Deutsch Kit

## Integrated Blindspot Safety System

**Includes: Heavy-duty FMCW 24GHz Sentry Radar, PreView Plus 7" Monitor, 1 camera, 18m / 59' body harness, 9m / 30' Heavy-Duty Body Harness with Deutsch Connectors, 90° Sensor Mounting Bracket**



### Tech Specs

#### Measuring Performance

Range	Prec-configured detection range - see parts table
Range Accuracy	0.3m
Azimuth Field of View	±75 degrees (10 dBsm target)
Elevation Field of View	±10 degrees (10 dBsm target)
Angle Accuracy	±2° @ ±10° FOV, ±5 @ ±30° FOV, ±10 @ ±75° FOV
Velocity Range	± 9 m/sec (± 20 mph)
Target Resolution	1.4 m for static targets, approaching 0.3 m for dynamic targets
Cycle Time	120 ms (A CAN bus target message is provided in every cycle.)
Water Tightness	IP 68 - IP 69K
Operating Temp	-40°C to +60°C
Salt Spray	ISO 9227
Housing	Plastic Aluminum
Lens	Hardened glass
Reflector	Free from reflector
Warranty	5 Years

#### Operating Conditions

Frequency	24.00 – 24.25 GHz
Power Supply	9 – 33 VDC, Reverse polarity and over-voltage protected
Current	<0.5 A
Operating Temperature	-40°C to +85°C
Storage Temperature	-55°C to +105°C
Shock	50G
Vibration	25 G, random, all three axis
Protection Rating	IP69K

#### Operating Modes

Detection Pattern	Fixed based on model number
Target Detection Time	300 ms
Power On to Active Time	300 ms

#### Communications Interface

J1939 CAN Bus	250 Kbits/sec, terminated with 120 ohm resistor
LED Interface	Switch to ground, sink up to 1A, over current protected

#### Physical Characteristics

Sealing	IP69K
Housing Material	Polycarbonate radome
Dimensions	4.90" (w) x 4.06" (h) x 1.28" (d) (12.4 cm x 10.3 cm x 3.25 cm)
Weight	13 lb (5.9 kg)
Mounting	Four 0.22" (5.6 mm) diameter mounting holes

### Description

This Preview Sentry Deutsch Kit is a plug-and-play heavy-duty radar solution with a pre-configured sensor range. The kit comes with the FMCW 24GHz Sentry radar sensor, 1 x PreView Plus Camera, 7" colour monitor, 18m / 59' camera extension, 9m / 30' heavy-duty body harness with Deutsch connectors, and a 90° sensor mounting bracket.

### Features and Benefits

- All-in-one Safety System Integrates Vision with Active Blind Spot Detection
- Combines best in class active blind spot detection radar with visual clarification camera and in-cab monitor
- PreView Plus provides operators with a heavy duty, all-in-one safety system by integrating a camera and monitor with Preco's patented radar sensor, operators have a single solution for active blind spot monitoring.

### Applications

Heavy-duty object detection

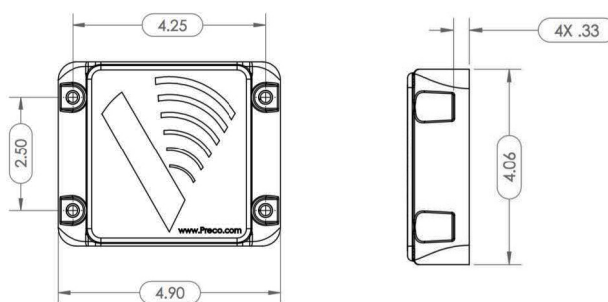

#### Part No.

#### Description

PV-PST85043	PreView Sentry Basic System w/ 4.5 x 3mtr sensor range + PreView Plus Camera System Upgrade.
-------------	--



Authorised Importer and Master Distributor

