

LIGHTING CATALOG 2022



ABL SHD 8000 / 12000 LED

Modular Heavy Duty LED Work Light



The new LED8000 and LED12000 from ABL represent their largest lumen output fixtures to date. It is perfect for high vibration applications such as drills, dozers, excavators and graders, where extra light is of paramount importance. Whilst a bullet proof high lumen fixture is this units main application, it can also serve other purposes, combining signal lighting and forward lighting into the one package.

Its customizable modular design can allow for combinations such as flood (work light) and long range (high beam) to be mixed in the one unit or it can be used as an all in one flood, long range, brake and indicator light. The options are endless.

Features

Drills, Dozers, Excavators and Graders

Tech Specs

Light Pattern	Flood Asymmetric, Flood, Long Range and Mixed Modules
Voltage	12-24V DC
Current	3.7A @ 24V (SHD8000), 6A @ 24V (SHD12000)
Connector	DT 2 pin, DT2V
Housing Material	Full aluminium with Inox bracket
EMC	ISO 13766 - ISO 14982 - ISO 12985 - CISPR25 Classe 3 to 5
IP Rating	IP68/69K
Consumption	90W (SHD8000), 144W (SHD12000)
Weight	8kg
Operational Lumen	8 - 10,000 Lumen (SHD8000) or 12 - 15,000 Lumen (SHD12000)
Color Temperature	6000°K
Load Dump	36V Continuous / ISO 7637-2 Pulse 5a
Polarity	Protected against reverse voltage
ETM	Full output at +35°C ambient, 25 % dimmed at + 50°C ambient
Vibration Resistance	15 Grms, from 24Hz to 2000Hz
Warranty	5 Years

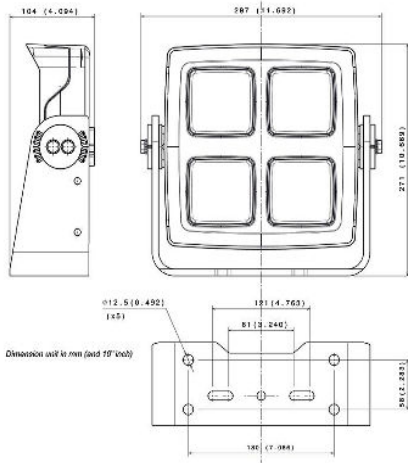

Part No.	Beam	Lumens	Voltage	Amps	Watts
SHD8000FA	Flood Asymmetric	8 - 10,000Lu	12-24V	3.7A @ 24V	90W
SHD8000F	Flood	8 - 10,000Lu	12-24V	3.7A @ 24V	90W
SHD8000LR	Long Range	8 - 10,000Lu	12-24V	3.7A @ 24V	90W
SHD12000FA	Flood Asymmetric	12 - 15,000Lu	12-24V	6A @ 24V	144W
SHD12000F	Flood	12 - 15,000Lu	12-24V	6A @ 24V	144W
SHD12000LR	Long Range	12 - 15,000Lu	12-24V	6A @ 24V	144W
SHD12000F-VW	Flood Warm White 3500K	12 - 15,000Lu	12-24V	6A @ 24V	144W
SHD12000LR-VW	Long Range Warm White 3500K	12 - 15,000Lu	12-24V	6A @ 24V	144W

Mix light patterns and colours

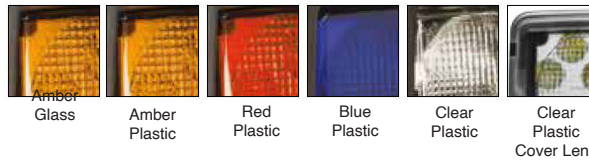
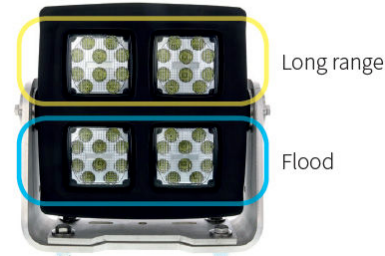

SHD8000 Lens Color Options:

SHD8000: 4x ST2000
SHD12000: 4x LED3000-500

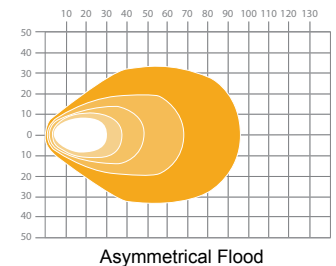
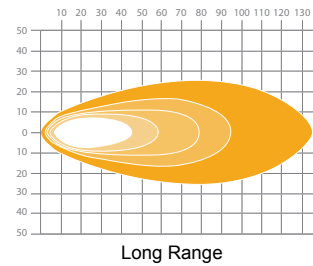
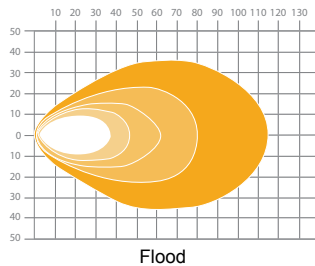
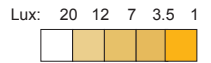

Part No.	Description
SHD8000CLR.F	Custom 2 Long Range, 2 Flood
SHD8000CLR.FAR	Custom 1 Long Range, 1 Flood, 1 Amber , 1 Red



ABL 2500 Series

5 YEAR WARRANTY

LED5000, LED3000

The 2500 Series ABL (5"x5") Halogen work lamps have long been the OE standard for a wide variety of heavy equipment. The 2500 LED Series, which includes the LED5000 and the LED3000 is ABL's flagship range of heavy-duty LED work lights. Both models feature the new extremely robust AVB bracket that has a tested shock rating of 80G and a vibration rating of 30Grms over 10-2000Hz.

AVB heavy-duty bracket



Quick Tech Specs

Shock Rating	80G
Vibration Rating	30Grms over 10-2000Hz
EMC	ISO 13766, 14982, 12985
Surge Protection	110V continuous, 200V 100ms, 1800V 50µs
Polarity	Protected against reverse voltage
IP Rating	IP68, IP69K
Operating Temp	-40°C to +85°C
Color Temp	6000K (std), amber optional

ABL LED5000

The ABL LED5000 draws 2.4A at 24V (57W) yet it outputs an impressive 5,000 effective lumens. 2.5X more effective lumens than your standard HID Xenon work lamp. Class leading surge protection, protected lens and IP69K sealed electronics make this a superior low draw, high output extreme duty work light.



Features

- AVB mount (std) 80G shock
- Lens: hardened glass
- Dim (DxWxH): 4.33x5.51x6.259" (110x140x159mm)
- Weight: 4.0 lbs (1.8kg)

Application: High-vibration heavy equipment, construction, forestry, agriculture

Beam:

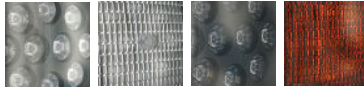

Flood Wide Flood Long Range Amber

Part No.	Beam	eLumens	rLumens	Voltage	Amps (24V)	Watts
LED5000F-MV	Flood	5000 Lu	6500 Lu	12-100V multi	2.4A	57W
LED5000WF-MV	Wide Flood	5000 Lu	6500 Lu	12-100V multi	2.4A	57W
LED5000LR-MV	Long Range	5000 Lu	6500 Lu	12-100V multi	2.4A	57W
LED5000A-MV	Amber	N/A	N/A	12-100V multi	2.4A	57W
LED5000F-24	Flood	5000 Lu	6500 Lu	24V	2.4A	57W
LED5000WF-24	Wide Flood	5000 Lu	6500 Lu	24V	2.4A	57W
LED5000LR-24	Long Range	5000 Lu	6500 Lu	24V	2.4A	57W

Lux: 20 12 7 3.5 1

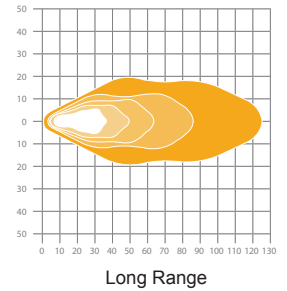
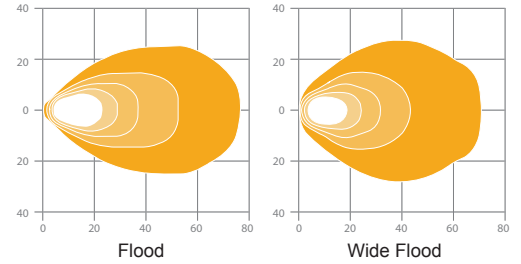
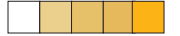

ABL LED3000

The ABL LED3000 has the same current draw as a HID Ballast work lamp (40W) yet it outputs an impressive 3,000 effective lumens. 35% more effective lumens with no additional current draw! Class leading surge protection, protected lens and IP69K sealed electronics make this a superior low draw, high output extreme duty work light.



Features

- AVB mount (std) 80G shock
- Lens: hardened glass
- Dim (DxWxH): 4.33x5.51x6.259" (110x140x159mm)
- Weight: 4.0 lbs (1.8kg)

Application: High-vibration heavy equipment, construction, forestry, agriculture

Beam:

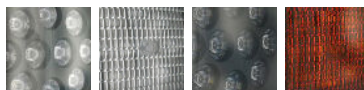

Flood Wide Flood Long Range Amber

Part No.	Beam	eLumens	rLumens	Voltage	Amps (24V)	Watts
LED3000F-MV	Flood	3000 Lu	4200 Lu	12-100V multi	1.7A	40W
LED3000WF-MV	Wide Flood	3000 Lu	4200 Lu	12-100V multi	1.7A	40W
LED3000LR-MV	Long Range	3000 Lu	4200 Lu	12-100V multi	1.7A	40W
LED3000A-MV	Amber	N/A	N/A	12-100V multi	1.7A	40W
LED3000F-24	Flood	3000 Lu	4200 Lu	24V	1.7A	40W
LED3000WF-24	Wide Flood	3000 Lu	4200 Lu	24V	1.7A	40W
LED3000LR-24	Long Range	3000 Lu	4200 Lu	24V	1.7A	40W

Lux: 20 12 7 3.5 1

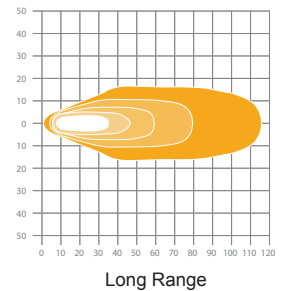
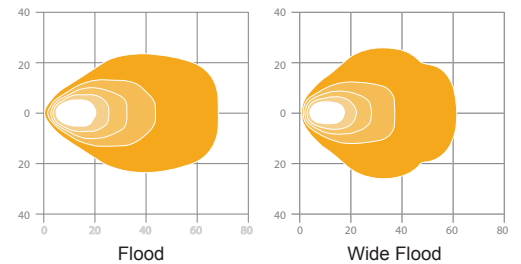

ABL 500 Series

LED3000, LED2000

The ABL 500 LED series work lights are designed to exceed everyday demands in all applications ensuring the highest efficiency and durability in even the harshest operating conditions.

Lens Options

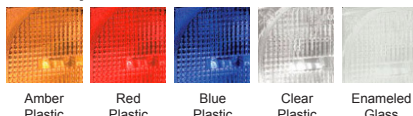

Quick Tech Specs

Shock Rating	60G
Vibration Rating	15Grms over 24-2000Hz
EMC	ISO 13766, 14982, 12985
IP Rating	IP68, IP69K

ABL LED3000

The ideal work light for mobile plant and equipment, ABL's LED3000-500 Series offer an exceptional output for such a low wattage fixture, with six LEDs producing 3000 effective lumens from just 36W. Compact and lightweight with class leading EMC and IP ratings, the LED3000-500 is available in 24V DC and multi voltage configurations with wide flood, flood, flood asymmetric and long range beam patterns. Ideal for the harsh operating conditions found in the mining, construction, forestry and agriculture industries, the fixture also comes with the option of a warm white colour temperature that is ideal for foggy and dusty environments.



Features

- 6 LEDs produce 3000 effective Lumens from 36W
- Pedestal & suspended mounting options
- IP68, IP69K rating
- 15Grms @ 24-2000Hz Vibration
- 60G Shock rating
- Wide Flood, Flood, Long Range, and Asymmetrical Flood
- Lens: hardened glass
- Dim (DxWxH): 3.15x4.016x5.197" (80x102x132mm)
- Weight: 1.98 lbs (0.9kg)

Application: Construction, mining, support vehicles, material handling, agriculture, forestry

Part No.	Beam	eLumens	rLumens	Voltage	Amps (24V)	Watts
LED3000-500F	Flood	3000 Lu	N/A	12-100V multi	1.5A	36W
LED3000-500WF	Wide Flood	3000 Lu	N/A	12-100V multi	1.5A	36W
LED3000-500LR	Long Range	3000 Lu	N/A	12-100V multi	1.5A	36W
LED3000-500F-24	Flood	3000 Lu	N/A	24V	1.5A	36W
LED3000-500WF-24	Wide Flood	3000 Lu	N/A	24V	1.5A	36W
LED3000-500LR-24	Long Range	3000 Lu	N/A	24V	1.5A	36W
LED3000-500FA	Asymmetrical	3000 Lu	N/A	12-100V	1.5A	36W
LED3000-500FA-24	Asymmetrical	3000 Lu	N/A	24V	1.5A	36W

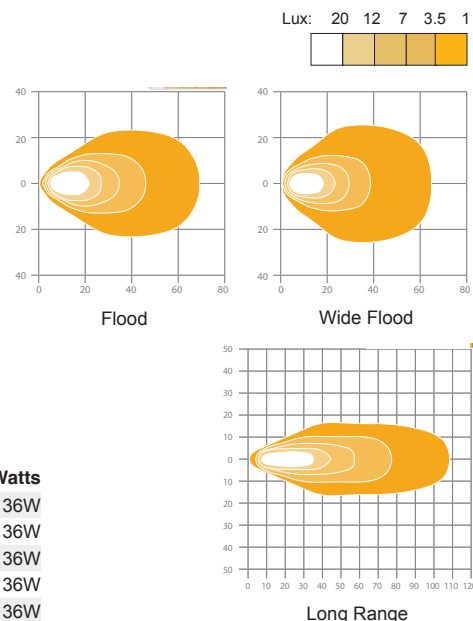

Asymmetrical version



- Optics direct a lot more light onto areas previously left in the dark by standard flood beam patterns.
- Increases vertical spread of light, non-symmetrically, to cover the immediate front working area without sacrificing light output further in front of the vehicle or machine.
- Enhances visibility, safety, and comfort for close-range demanding applications or where extra-wide angles are needed.

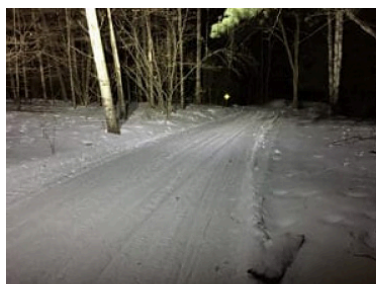
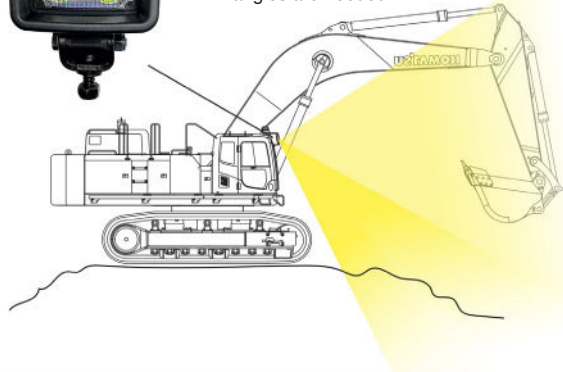

Standard Flood Beam

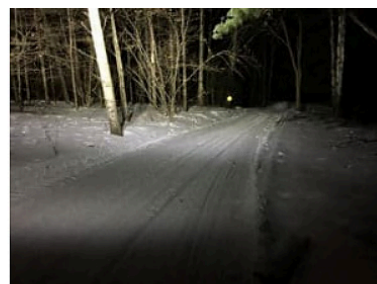

Asymmetrical Flood Beam

Colour options



Blue



Amber

Colour-coded labels for easy identification

Colour-coded labels provide an instant visual on-shelf guide to the various beam patterns, providing ease of identification to ensure the correct beam pattern is selected and installed.



ABL LED2000

ABL LED2000 in the 500 Series is a new multi-volt (12-24V, 12-80V, 24V only) LED work lamp offering a direct substitution for your 12V 55W & 24V 70W Halogen and 35W HID.



Features

- Salt Spray: ISO 9227
- Lens: hardened glass
- Dim (DxWxH): 3.15x4.016x5.197" (80x102x132mm)
- Weight: 1.98 lbs (0.9kg)

Application: Material handling, heavy equipment, mining, construction, agriculture, forestry, utility vehicles, marine

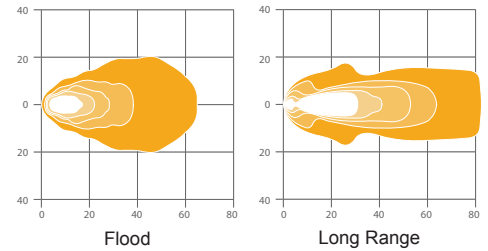

Part No.	Beam	eLumens	rLumens	Voltage	Amps (24V)	Watts
LED2000F-1280	Flood	2000 Lu	2500 Lu	12 / 80V	1.2A	28W
LED2000LR-1280	Long Range	2000 Lu	2500 Lu	12 / 80V	1.2A	28W
LED2000F-24V	Flood	2000 Lu	2500 Lu	24V	1.2A	28W
LED2000LR-24V	Long Range	2000 Lu	2500 Lu	24V	1.2A	28W
LED2000AFP-1280	Amber	N/A	N/A	12 / 80V	1.2A	28W

ABL LED1000

The ABL LED1000 is a heavy-duty LED work light that outputs 1000 Lumens from only 14W of power. It's built tough with a hardened glass lens, IP68 and IP69K ingress protection, 60G shock and 15 Grms @ 24Hz-2000Hz vibration rating. It also features EMC CISPR25 class 5 certification making it suitable for heavy vehicles and machinery in mining and construction.



Features

- Lens: hardened glass
- 60G shock, 15Grms @ 24-2000Hz vibration
- IP Rating: IP68, IP69K
- Protected against reverse voltage
- 2 Year Warranty
- Dim (DxWxH): 3.15x4.0x3.86" inches (80x102x98mm)
- Weight: 1.98 lbs (0.9kg)

Application: Heavy equipment, mining, construction, support vehicles, material handling, agriculture, forestry

Part No.	Beam	Voltage	Amps (24V)	Watts
LED1000F	Flood	12-24V DC	0.58A	14W

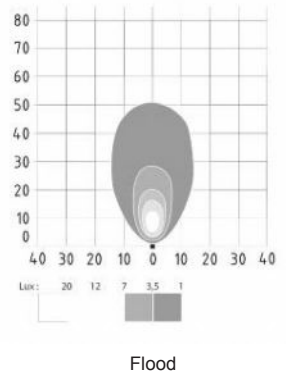

ABL 'No Glare' LED Work Light Range



No-glare optics projects light forward and down forming a cut-off line, allowing the road or worksite to be illuminated without blinding on-coming traffic or workers. Creates a safer work environment and reduces fatigue.

Benefits

- Reduces fatigue on personnel due to harsh light shining in their eyes
- Get just the right amount of light with 2000, 1500, 1000 lumen options.
- Built to OEM spec
- Suitable for mining, construction, civil, ports, utilities

Specs

- 15Grms @ 24-2000Hz vibration and 60G shock
- CISPR 25 Class 5
- IP68 & IP69K

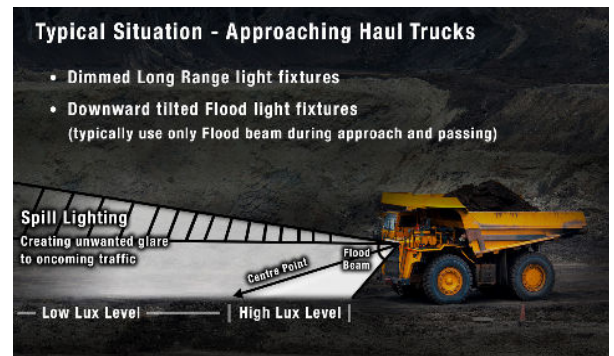

ABL Round Compact Series

RL LED1000, RT LED1500, RLA LED2000

ABL RL LED1000

The ABL RL LED1000 is a compact LED-powered work lamp. This 14W version features 6 LED bulbs and pumps out an impressive 1000 lumens. This lamp exceeds everyday demands in all applications from handling equipment to heavy vehicles.



Features

- Lens: hardened glass
- 60G shock, 15Grms @ 24-2000Hz vibration
- IP Rating: IP68, IP69K
- Protected against reverse voltage
- 4 Year Warranty
- Dim (DxWxH): 3.03x3.58x5.07" inches (77x91x129mm)
- Weight: 0.9 lbs (0.45kg)



Application: Heavy equipment, mining, construction, road and utility equipment, forestry, agriculture

Part No.	Beam	Voltage	Amps (24V)	Watts
RL1000F	Flood	12-24V DC	0.58A	14W
RL1000LR	Long Range	12-24V DC	0.58A	14W
RL1000FA	Asymmetrical Flood	12-24V DC	0.58A	14W

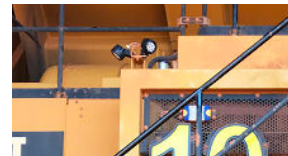

Lux: 20 12 7 3.5 1

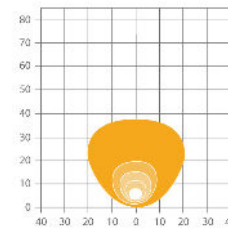

Asymmetrical Flood

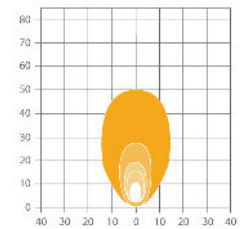

Flood

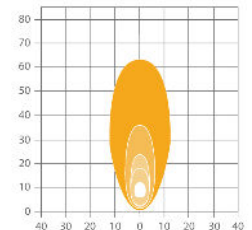

Long Range

ABL RT LED1500

The ABL RT LED1500 is a compact LED-powered work lamp. This 20W version features 6 LED bulbs and pumps out an impressive 1500 lumens. This lamp exceeds everyday demands in all applications from handling equipment to heavy vehicles.



Features

- Lens: hardened glass
- 60G shock, 15Grms @ 24-2000Hz vibration
- IP Rating: IP68, IP69K
- Protected against reverse voltage
- 4 Year Warranty
- Dim (DxWxH): 3.03x3.58x5.07" inches (77x91x129mm)
- Weight: 1.2 lbs (0.55kg)

Application: Heavy equipment, mining, construction, road and utility equipment, forestry, agriculture

Part No.	Beam	Voltage	Amps (24V)	Watts
RT1500F	Flood	12-24V DC	0.85A	20W
RT1500LR	Long Range	12-24V DC	0.85A	20W
RT1500FA	Asymmetrical Flood	12-24V DC	0.85A	20W

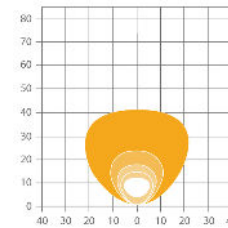
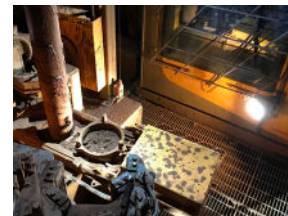

Asymmetrical Flood

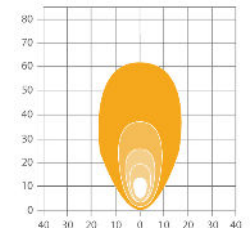

Flood

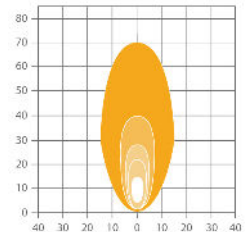

Long Range

ABL RLA LED2000

The ABL RLA LED2000 is a compact LED-powered work lamp. This 29W version features 6 LED bulbs and pumps out an impressive 2000 lumens. This lamp exceeds everyday demands in all applications from handling equipment to heavy vehicles.



Features

- Lens: hardened glass
- 60G shock, 15Grms @ 24-2000Hz vibration
- IP Rating: IP68, IP69K
- Protected against reverse voltage
- 4 Year Warranty
- Dim (DxWxH): 3.03x3.58x5.07" inches (77x91x129mm)
- Weight: 1.3 lbs (0.60kg)

Application: Heavy equipment, mining, construction, road and utility equipment, forestry, agriculture

Part No.	Beam	Voltage	Amps (24V)	Watts
RLA2000F	Flood	12-24V DC	1.2A	29W
RLA2000LR	Long Range	12-24V DC	1.2A	29W
RLA2000FA	Asymmetrical Flood	12-24V DC	1.2A	29W

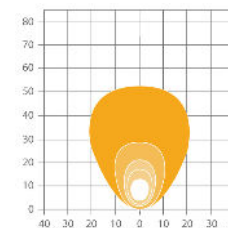
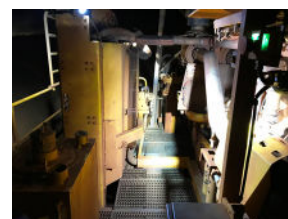

Asymmetrical Flood

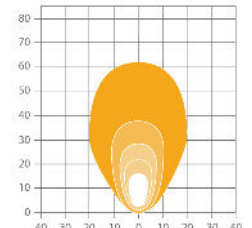

Flood

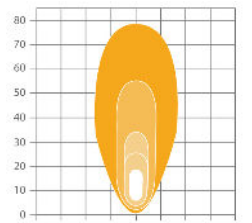

Long Range



ABL Square Compact Series

SL LED1000, ST LED1500, SLA LED2000

ABL SL LED1000

The ABL SL LED1000 is a standard work light with R23 reverse approval that includes features such as 1000 lumens, 14 watts and EMC CISPR25 class 5 as well as the integrated load dump to meet the most severe specifications.



Features

- Lens: hardened glass
- 60G shock, 15Grms @ 24-2000Hz vibration
- IP Rating: IP68, IP69K
- Protected against reverse voltage
- 4 Year Warranty
- Dim (DxWxH): 2.24x3.97x3.81" inches (57x101x97mm)
- Weight: 0.9 lbs (0.45kg)

Application: Heavy equipment, mining, construction, road and utility equipment, forestry, agriculture

Part No.	Beam	Voltage	Amps (24V)	Watts
SL1000F	Flood	12-24V DC	0.58A	14W
SL1000LR	Long Range	12-24V DC	0.58A	14W
SL1000FA	Asymmetrical Flood	12-24V DC	0.58A	14W

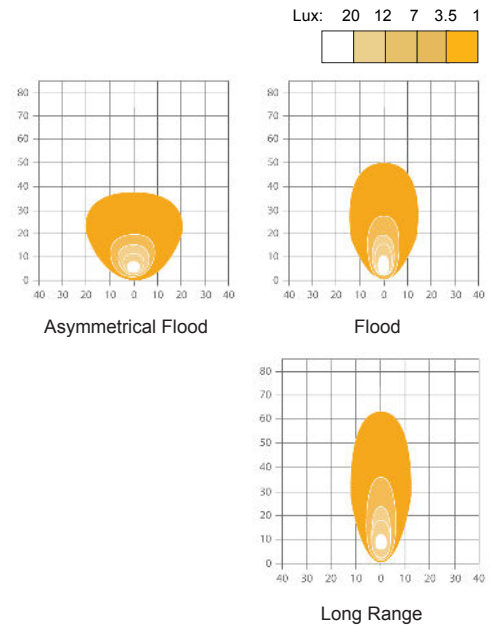

ABL ST LED1500

The ABL ST LED1500 is a standard work light that includes features such as 1500 lumens, 20 watts and EMC CISPR25 class 5 as well as the integrated load dump to meet the most severe specifications.



Features

- Lens: hardened glass
- 60G shock, 15Grms @ 24-2000Hz vibration
- IP Rating: IP68, IP69K
- Protected against reverse voltage
- 4 Year Warranty
- Dim (DxWxH): 2.24x3.97x3.81" inches (57x101x97mm)
- Weight: 1.10 lbs (0.5kg)

Application: Heavy equipment, mining, construction, road and utility equipment, forestry, agriculture

Part No.	Beam	Voltage	Amps (24V)	Watts
ST1500F	Flood	12-24V DC	0.85A	20W
ST1500LR	Long Range	12-24V DC	0.85A	20W
ST1500FA	Asymmetrical Flood	12-24V DC	0.85A	20W

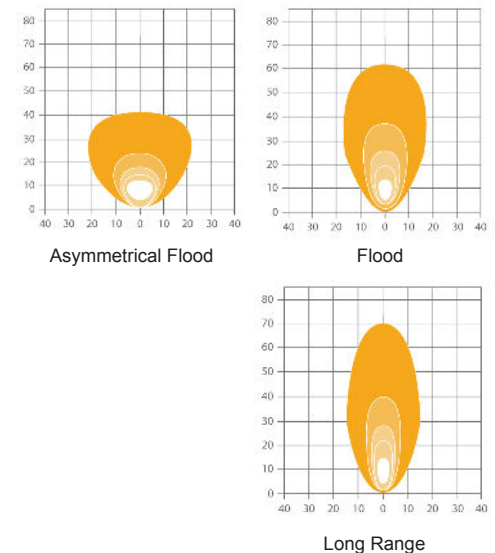

ABL SLA LED2000

The ABL SLA LED2000 is a standard work light that includes features such as 2000 lumens, 29 watts and EMC CISPR25 class 5 as well as the integrated load dump to meet the most severe specifications.



Features

- Lens: hardened glass
- 60G shock, 15Grms @ 24-2000Hz vibration
- IP Rating: IP68, IP69K
- Protected against reverse voltage
- 4 Year Warranty
- Dim (DxWxH): 2.24x3.97x3.81" inches (57x101x97mm)
- Weight: 1.21 lbs (0.55kg)

Application: Heavy equipment, mining, construction, road and utility equipment, forestry, agriculture

Part No.	Beam	Voltage	Amps (24V)	Watts
SLA2000F	Flood	12-24V DC	1.2A	29W
SLA2000LR	Long Range	12-24V DC	1.2A	29W
SLA2000FA	Asymmetrical Flood	12-24V DC	1.2A	29W

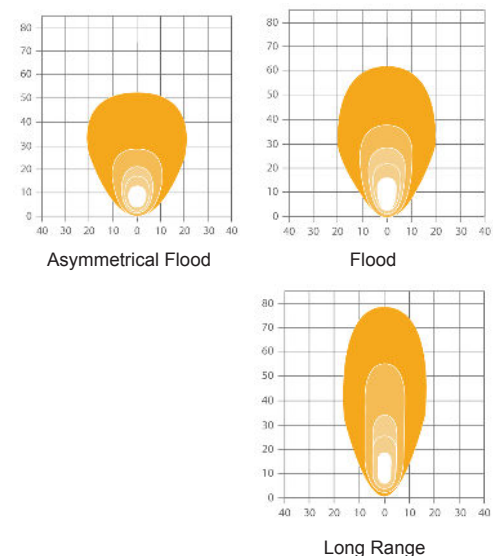

ABL LED BLUE

The LED BLUE in the 500 Series is designed for applications where a highly visible sharp-edged warning signal on the floor is required for an increased safety environment. This light is often suitable for use on forklifts providing additional safety and visibility for personnel in warehouses or stores.



Features

- Sharp-edged spot
- 10 Grms over 24 to 2000Hz
- EMC: ISO 12985
- Dim (DxWxH): 4.84x4.291x5.197" (123x109x132mm)
- Weight: 2.2 lbs (1.0kg)

Application: Forklifts

Part No.	Beam	Voltage	Amps (24V)	Watts
ABL-LED500BLUE	Spot	12-100V multi	0.2A	5W

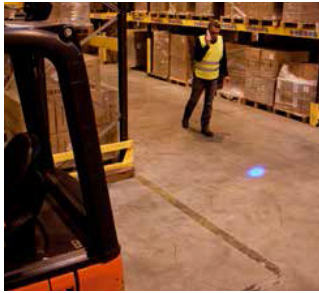

ABL XENON HD

The Xenon HD 500 Series work light is one of the most compact, powerful Xenon HID lights available. With 3 axis vibration dampeners and an integrated ballast, the Xenon HD is designed for heavy-duty applications. Xenon/HID simulates daylight giving the most consistent light patterns for your operators.



Features

- 15 Grms over 24 to 2000Hz
- EMC: ISO 13 766, 14 982
- IP Rating: IP66, IP69K
- Salt Spray: ISO 9227
- Dim (DxWxH): 5.905x4.094x5.118" (150x104x130mm)
- Weight: 2.2 lbs (1.0kg)

Application: Forklifts, warehouses, stores

Part No.	Beam	Voltage	Amps (24V)	Watts
500-X12F35IB	Flood	12V	N/A	35W
500-X12LR35IB	Long Range	12V	N/A	35W
500-X12T35IB	Trapezoid	12V	N/A	35W
500-X24F35IB	Flood	24V	1.8A	35W
500-X24LR35IB	Long Range	24V	1.8A	35W
500-X24T35IB	Trapezoid	24V	1.8A	35W

Lux: 20 12 7 3.5 1

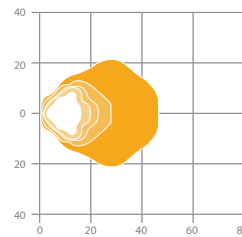

Flood

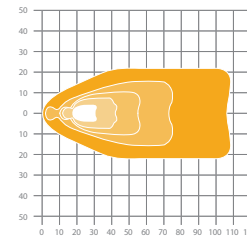

Long Range

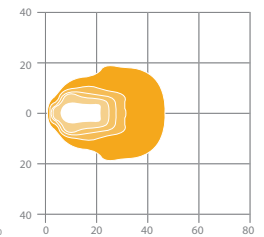

Trapezoid

ABL 3800 LED Driving Light

The ABL 3800 Combination Drive light is SAE / DOT / ECE approved for on-road and off-road vehicles. The clear glass lens and free-form reflector provide ideal road illumination in an innovative but rugged and durable design. Along with numerous mounting operations, this light incorporates a moisture-eliminating breather, parking light, and an optional side repeater. These options allow this light to be customized for use on any vehicle globally. With numerous mounting operations, the high vibration performance of this full LED combination light allows industrial vehicles to endure extreme working conditions with virtual-free maintenance for their homologated driving lights package.



Features

- 15 Grms over 24 to 2000Hz
- EMC: ISO 13 766, ISO 14 982, ISO 12 895, CISPR25 Class 3
- IP Rating: IP68, IP69K
- Salt Spray: ISO 9227
- Dim (DxWxH): 5.0x9.45x8.3" (127x240x211mm)
- Weight: 4.3 lbs (1.9kg)

Application: Construction, Agriculture, Off-Road Equipment, Plow Truck (e.g. Snow Plow)

Part No.	Voltage	Amps (24V low beam)	Amps (24V high beam)	Watts (low beam)	Watts (high beam)	Mounting Option
3800LED-12/24-P	12-24V multi	1.29A	0.85A	32W	22W	Pedestal
3800LED-12/24-R	12-24V multi	1.29A	0.85A	32W	22W	Rear
3800LED-12/24-S	12-24V multi	1.29A	0.85A	32W	22W	Suspended
3800LED-12/24-VL	12-24V multi	1.29A	0.85A	32W	22W	Vertical Left
3800LED-12/24-VR	12-24V multi	1.29A	0.85A	32W	22W	Vertical Right
3800LED-12/24-VRE	12-24V multi	1.29A	0.85A	32W	22W	Vertical Rear

