

ABL No Glare 1500 Lu LED Work Lamp

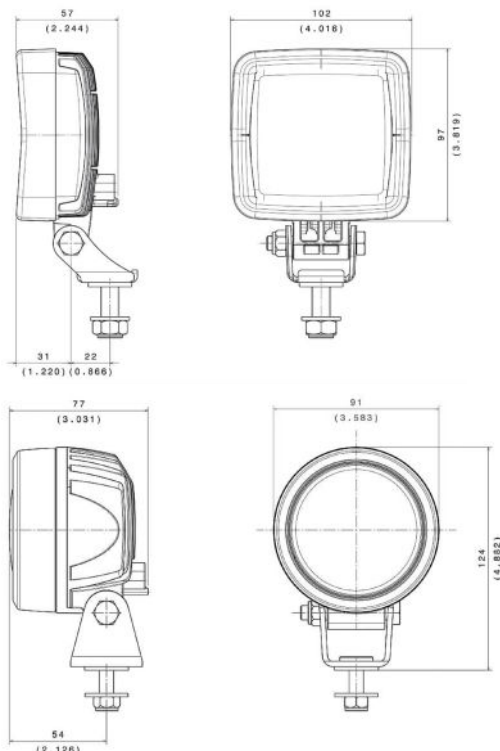

Description

The ABL No Glare 1500 Lumen LED work light fixtures, which include both the ST1500NG square and RT1500NG round lights are suitable for motor graders and construction vehicles where glare needs to be safely reduced/eliminated for other oncoming vehicles.

With standard work lamps, the light is spread out hitting not only the intended worksite but also the surroundings. The ABL No Glare optics pushes the light emitted from the fixture forward and down forming a cut-off line. This anti glare feature allows it to light up only where it's needed, which increases the safety and comfort of drivers and workers. The perfect solution for motor graders and construction vehicles.

The ST1500NG and RT1500NG include features such as the EMC CISPR25 class 5 and integrated load dump. Built tough, having both IP68 and IP69K certification and 60G shock rating, this zero glare light meets the most severe of manufacturers' specifications. Also suitable for OEM, and replacement of existing 24V dual 55W/70W halogen lights.

Features and Benefits

- LED with 'No Glare' optical module
- 1500 effective Lumens
- Meets CISPR 25 Class 5 standards
- Connector: DT 2 pin
- Hardened glass Lens
- IP68, IP69K ingress protection
- 15 Grms @ 24-2000Hz vibration resistance
- 60G shock rating
- EMC: ISO 13766, ISO 14982, ISO 12985, CISPR25 Class 5

Applications

OEM, Light vehicles (LVs), utility vehicles, forklifts, material handling, construction, forestry, agriculture

Tech Specs

Tech	LED
Beam Pattern	No Glare optics
Lumens	1500 effective Lumens
Wattage	20W
Voltage	12-24V DC
Polarity	Protected against reverse voltage
Load Dump / Surge Dump	Surge: 36V continuous / ISO 7637-2 Pulse 5a
Current	0.85A @ 24V DC
Connector	DT 2 pin
Vibration Resistance	15 Grms @ 24-2000Hz
Shock Resistance	60G
IP Rating	IP68, IP69K
EMC	ISO 13766, ISO 14982, ISO 12985, CISPR25 Class 5
Salt Spray Test	ISO 9227
Operating Temperature	-40°C to +85°C
Lens Material	Hardened glass, Plastics
Mounting	Pedestal, suspended
Dimensions (DxWxH)	2.24x4.0x3.82" inches (57x102x97mm)
Weight	0.9 lbs (0.45kg)
Warranty	4 Years

Part No.	Description
ST1500NG	No Glare optics, 1500 Lu, 12-24V DC, 0.85A, 20W
RT1500NG	No Glare optics, 1500 Lu, 12-24V DC, 0.85A, 20W

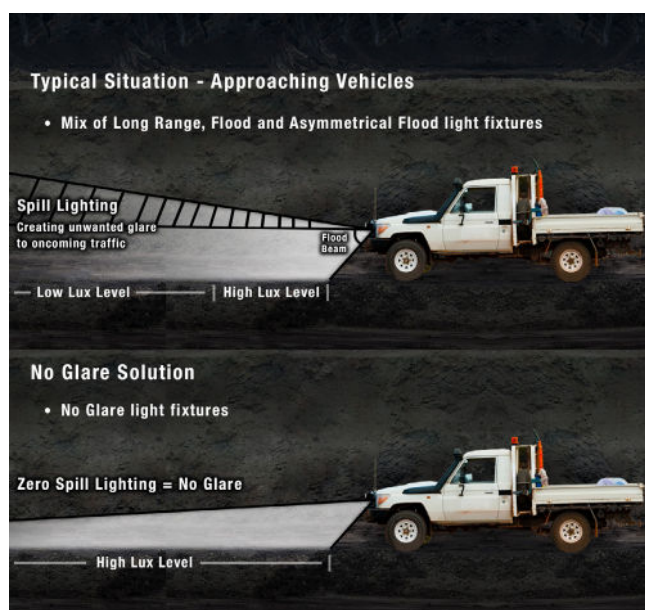

Authorised Importer and Master Distributor

