

ECCO EB8160 Series

Heavy Duty LED Beacon



Description

ECCO's EB8160 Series Heavy Duty Beacon keeps crews safe in the most rugged environments. A shatter-resistant lens and die-cast aluminum base maximize durability. This LED beacon measures light levels and auto-dimming LEDs adjust to deliver the perfect warning intensity, day or night. The EB8160 exceeds certification for low radio interference and is waterproof even under high pressure. On or off the job, this heavy-duty beacon is ideal for mining, agriculture or any other commercial vehicle application.

Features and Benefits

- 24 high-performance amber LEDs
- Permanent 3-bolt or vacuum mount option
- 57" lead wires for permanent 3 bolt models
- 15' cord with dual switch lighter adapter for "VM" models
- Die-cast aluminum base and shatter-resistant polycarbonate lens
- CISPR 25 certification ensures minimal interference with radio communications
- Ambient light detection and automatic dimming provide optimal light output at all times

Applications

Mining, agriculture or any other commercial vehicle application

Tech Specs

Voltage	10-30V DC
Amps	4.4A
Flash Patterns	20
LEDs	24
Mount	3-Bolt or Vacuum Mount
Temp. Range	-40°F to +140°F (-40°C to +60°C)
Certifications	SAE Class I, California Title 13, RCM, CISPR 25, IP67, IP69K, ECE Reg 10

Part No.	Description
EB8160A	3 Bolt Mount, Amber Lens Color, Amber LED Color
EB8160CA	3 Bolt Mount, Clear Lens Color, Clear LED Color
EB8160AVM	Vacuum Mount, Amber Lens Color, Amber LED Color
EB8160CAVM	Vacuum Mount, Clear Lens Color, Clear LED Color

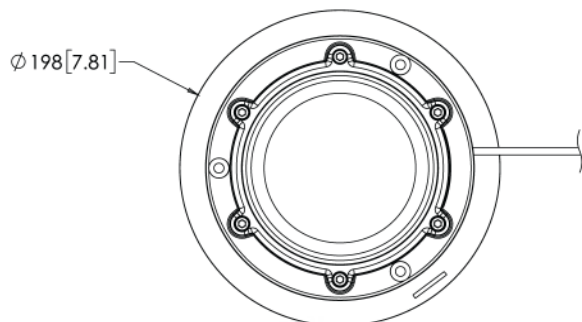
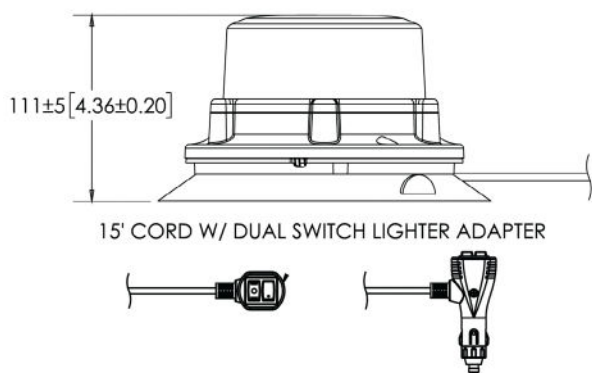

Authorised Importer and Master Distributor

